



**AEROMAX**  
Wireless Intercom

Rev 2.0

# Installation Manual



[www.max.us.com](http://www.max.us.com)



Patent Pend

A facility needs to be evaluated whether it is suitable for wireless application.  
Maximum Controls, LLC is not responsible for any mis-application of this product.

Please read the entire manual before installation.

# Warranty

**Maximum Controls, LLC, warrants, for twenty-four (24) months from the date of invoice, the Aeromax systems and other related systems and equipment manufactured by Maximum Controls, LLC, to be free from defects in material and workmanship under normal use and service for which it was intended provided it has been properly installed and operated.**

Maximum Controls, LLC's obligations under this warranty shall be limited to the repair or exchange of any part of parts manufactured by Maximum Controls, LLC. Defective products must be returned to Maximum Controls, LLC, freight prepaid by purchaser, within the warranty period. Items returned will be repaired or replaced, at Maximum Controls, LLC's option, upon an examination of the product by Maximum Controls, LLC, which discloses, to the satisfaction of Maximum Controls, LLC, that the item is defective. Maximum Controls, LLC will return the warranted item freight prepaid.

The products manufactured by Maximum Controls, LLC, are not warranted to meet the specific requirements, if any, of safety codes of any particular state, municipality, or other jurisdiction, and neither Maximum Controls, LLC, assume any risk or liability whatsoever resulting from the use thereof, whether used singly or in combination with other machines or apparatus.

Any products and parts not manufactured by Maximum Controls, LLC, will carry only the warranty, if any, of the manufacturer. This warranty shall not apply to any products or parts thereof which have been repaired or altered, without Maximum Controls, LLC's written consent, outside of Maximum Controls, LLC's production facility, or altered in any way so as, in the judgment of Maximum Controls, LLC, to affect adversely the stability or reliability of the product(s) or has been subject to misuse, negligence, or accident, or has not been operated in accordance with Maximum Controls, LLC's instructions or has been operated under conditions more severe than, or otherwise exceeding, those set forth in the specifications for such product(s). Maximum Controls, LLC, shall not be liable for any loss or damage whatsoever resulting, directly or indirectly, from the use or loss of use of the product(s). Without limiting the foregoing, this exclusion from liability embraces a purchaser's expenses for downtime or for making up downtime, damages for which the purchaser may be liable to other persons, damages to property, and injury to or death of any persons.

Maximum Controls, LLC, neither assumes nor authorizes any person to assume for them any other liability in connection with the sale or use of the products of Maximum Controls, LLC. This limited warranty extends only to wholesale customers who buy directly through Maximum Controls, LLC's normal distribution channels.

Consumers must inquire from their selling dealer as to the nature and extent of that dealer's warranty, if any. This warranty is expressly in lieu of all other warranties expressed or implied including the warranties of merchantability and fitness for use. This warranty shall not apply to products or any part thereof which have been subject to accident, negligence, alteration, abuse, or misuse or if damage was due to improper installation or use of improper power source, or if damage was caused by fire, flood, lightning, electrical power surge, explosion, wind storm, hail, aircraft or vehicles, vandalism, riot or civil commotion, or acts of God.



Figure \$

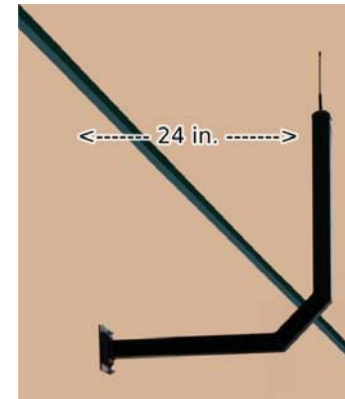

Figure %



Figure 10

**“Range Testing” Procedure:**

- 1) Position the pair of intercom units in their respective locations (as close to their final location as possible)
- 2) Power ON only a single pair of units (one Indoor and one Outdoor Intercom units) to perform a “Range Test”. All other Intercom units need to be turned OFF.
- 3) Ensure the “Outdoor” unit's antenna is min 8 feet above ground.
- 4) Flip the “TEST Switch” to ON position in the “RADIO SIGNAL TEST” section of the board on “Outdoor” unit. The “QUALITY” LED bar graph as well as the “LEVEL” and “HISTORY” LEDs will light up. The unit will now automatically initiate communication with the remote unit and provide the quality of the radio of the radio link between them. Primarily focus on the “QUALITY” LED bar graph for assessing the radio link (see figure 8).
- 5) If the “QUALITY” LED bar graph has more than 2 bars on, then the link is GOOD (Skip next step)
- 6) If the LED bar has less than 2 bars, then do the following to improve the range:
  - Move the “Outdoor” intercom unit (or their antenna using extensions) to different location and observe the “QUALITY” LED bar graph again to see if the range has improved.
  - Move the “Indoor” Intercom unit (or their antenna using extensions) to different location and observe the “QUALITY” LED bar graph again to see if the range has improved.Note: Repeat the steps above until the ideal location for antennas are determined.
- 7) If the building walls are metal reinforced and the “Range Test” results are poor, then the antenna of the “Indoor” Intercom unit may need to be mounted near a window – using antenna extension cable(s). For worst-case applications, the antenna may need to be mounted outside of the building (on outer wall) (see Figure 9). Again, utilize the “Range Test” feature to determine optimal position for antenna.
- 8) In applications where extreme range is required , high gain antenna may be utilized (see Figure 10).

**Table of Contents:**

Warranty .....	Page 1
Installation Guidelines .....	Page 3
Outdoor Unit Setup .....	Page 5
Indoor Installation .....	Page 7
Indoor Unit Setup .....	Page 9
Trouble Shooting .....	Page 11

## Installation Guidelines:

### Antenna installation:

- 1) Make sure Outdoor Unit antenna is installed min **8 feet** above ground. (This ensures good range and avoids antenna vandalism)
- 2) Ensure antenna is not installed against any metallic surface. To avoid reducing radio range install antenna at least 24" away from steel post or building structure (Figure 1).
- 3) After wire installation, ensure enclosure knockouts are properly sealed– to avoid water intrusion.

### Outdoor Unit installation:

- 1) Open enclosure - using key.
- 2) Disconnect 6-inch antenna extension cable inside enclosure.(Figure 2)
- 3) Remove the front door by removing the two hinge screws. (Figure 2)
- 4) Remove knockouts (back or bottom – as necessary) and fish wires through knockout.
- 5) Mount back enclosure using mounting holes.
- 6) Re-install front door using two hinge screws.
- 7) Re-connect 6-inch antenna extension cable inside enclosure.
- 8) Follow wiring and setup instructions for Outdoor Unit.
- 9) Run 6-foot antenna extension cable as necessary and mount antenna.
- 10) Screw 6-foot antenna extension cable on back of enclosure and run cable as necessary to antenna location.
- 11) Mount antenna and ensure that it is hand tight.

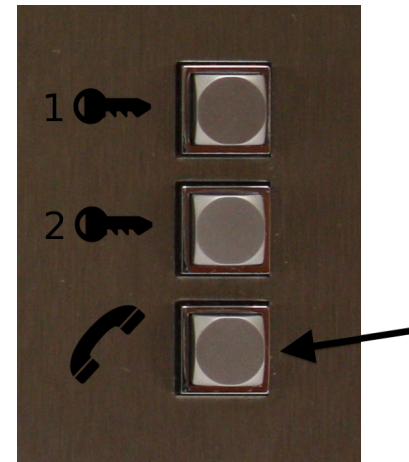

Figure 6

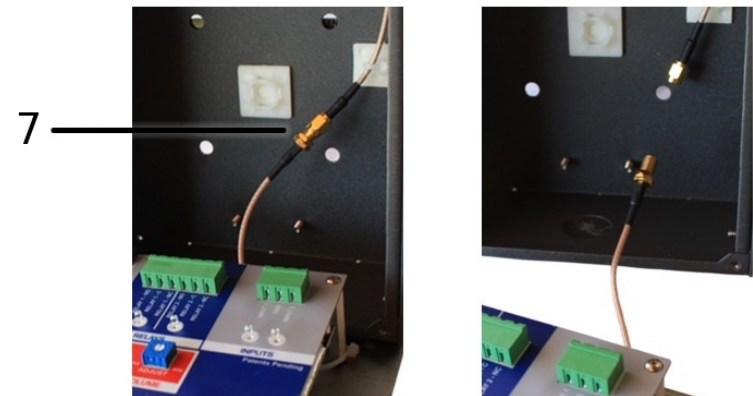

Figure 7

## Trouble Shooting:

### Unable to call remote unit (from Indoor or Outdoor intercom):

- 1) Ensure power is applied (check power input voltage using volt meter – needs to be 12V – 16V AC or DC).
- 2) Ensure TEST Switch in in OFF position in the “RADIO SIGNAL TEST” section of the board.  
Note: Intercom needs to be in Normal operation mode to call.
- 3) Ensure the RADIO CHANNEL positions on the “Outdoor” and “Indoor” units match
- 4) Ensure all “Outdoor” Intercom units have their “ACCESS PT” rotary switch set between 1-9 (not 0)
- 5) Check if the remote unit (Outdoor or Indoor) that you are calling is in “Idle” mode and not in “Voice Communication” mode (off-hook).  
- Push the “Call” switch on remote unit to ensure it hangs up (see figure 6).

Note: If remote unit is able to call other units, then it is in “Idle” mode.

- 6) Ensure that the antennas on all units are securely installed (hand tighten) (see figure 7).
- 7) Ensure any antenna extension cables are securely installed (hand tighten)
- 8) Keep the Intercom units away from any other radio devices, such as handheld radios-to avoid radio interference.
- 9) If all above is verified, and still unable to call, then perform a “Range Test” (see instructions below).

### Poor audio sound:

- 1) If audio has static (or other) noise, ensure the front door of the units are shut before initiating audio communication
- 2) If audio has feedback (static heard after speaking on *local* unit), lower the volume of the *remote* unit. This will reduce the sound echo feedback on the remote unit.

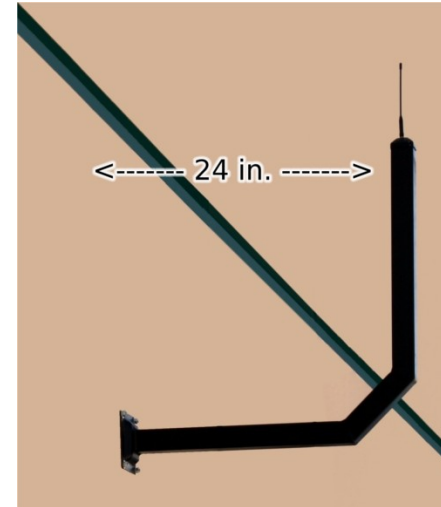

Figure 1

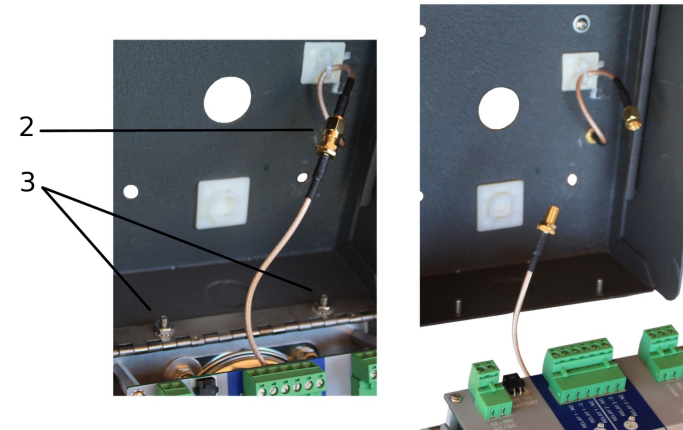

Figure 2

## Outdoor Unit Setup:

**Note:** Step numbers correspond to numbers in figure 3.

- 1) Install **Power Transformer** provided with system (avoid sharing the power transformers provided, to power other devices)
- 2) Adjust **Speaker Volume**
- 3) Select **Radio Channel (0-9)**
- 4) Select **Strike Times** for Relay 1 and Relay 2
- 5) Select **Access Point Number (1-9 for Outdoor Unit)**
- 6) a) To verify radio signal quality, turn on **Test Switch:**
  - Ensure remote Indoor unit is powered & turned ON
  - Set the radio channel of remote Indoor unit to same channel as Outdoor unit being tested
- b) Turn OFF TEST switch on remote Indoor unit
  - Start testing: observe Quality LED bar and position unit to obtain best signal quality
  - Turn OFF TEST switch after testing
- 7) Connect screw terminal to **Ground Rod** using 12 AWG wire – to ensure surge protection
- 8) Connect dry contact **Inputs**
  - “Exit” Switch (RTE)
  - “Call” Switch for vehicle auto call feature
- 9) Connect **Relay 1** and **Relay 2** Terminals to gate or door

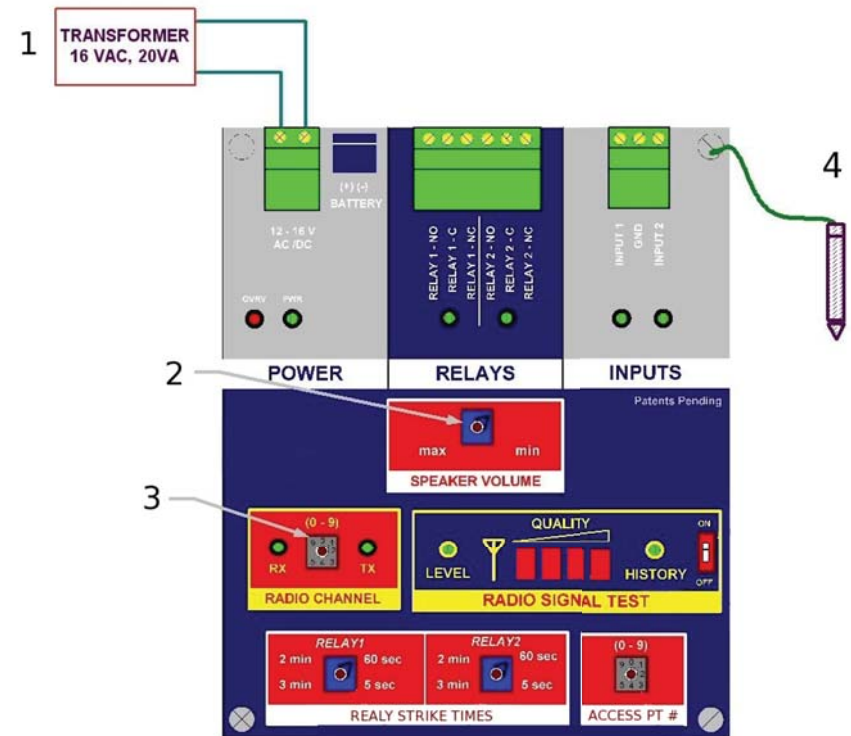

Figure 5

## Indoor Unit Setup:

**Note:** Step numbers correspond to numbers in figure 5.

- 1) Install **Power Transformer** provided with system (avoid sharing the power transformers provided, to power other devices)
- 2) Adjust **Speaker Volume**
- 3) Select **Radio Channel (0-9)**
- 4) Connect screw terminal to **Ground Rod** using 12 AWG wire – to ensure surge protection

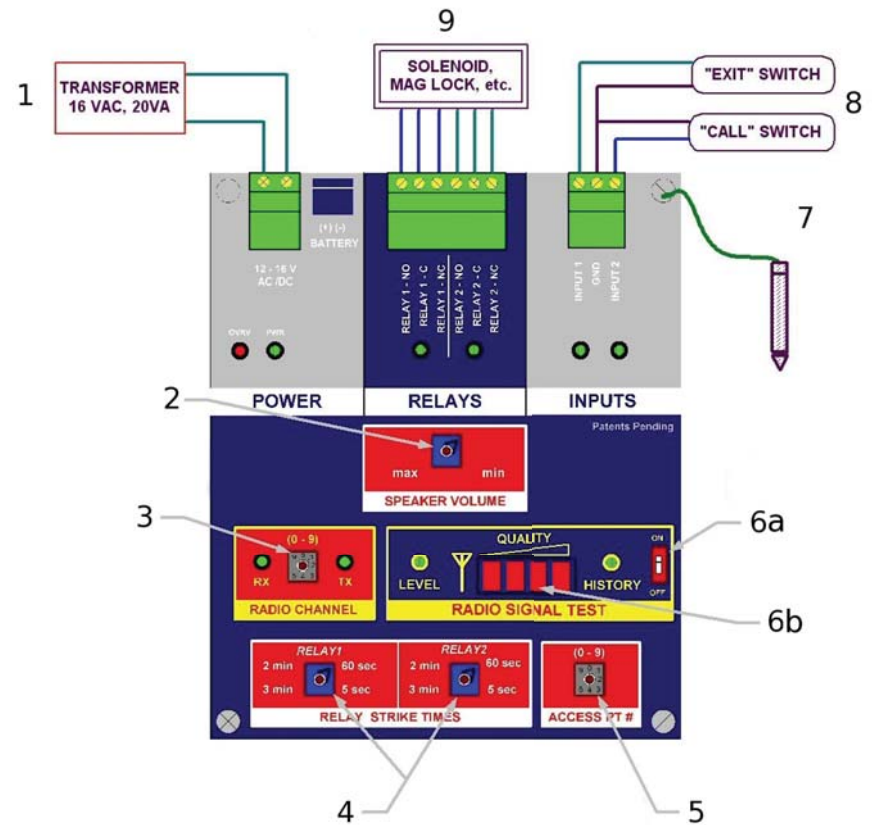

Figure 3

## ***Indoor Installation:***

### **Indoor Unit installation:**

- 1) Open enclosure by removing 4 screws.
- 2) Disconnect 6-inch antenna extension cable inside enclosure. (Figure 4)
- 3) Remove the front door.
- 4) Remove knockouts (back or bottom – as necessary) and fish wires through knockout.
- 5) Mount back enclosure using mounting holes.
- 6) Re-connect 6-inch antenna extension cable inside enclosure.
- 7) Follow wiring and setup instructions for Outdoor Unit.
- 8) Re-install front door using 4 screws.
- 9) Install antenna on top of enclosure and ensure that it is hand tight.

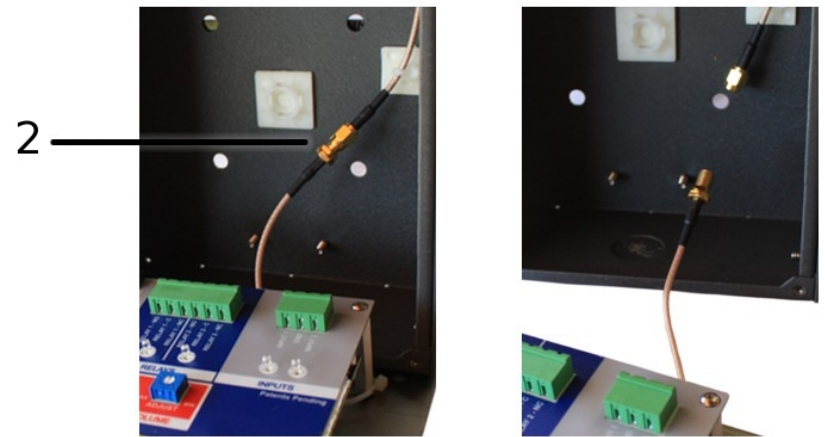

Figure 4